

# SCHONBEK®

SCHONBEK IS A WORLD LEADER IN CHANDELIER DESIGN. PATENTS INCLUDE:  
#D292,620, #D335,362, #D335,546, #D335,716,  
#D335,720, #D336,537, #D338,082, #D389,264,  
#D338,278, #D339,879, #D345,815, #D373,441,  
#D374,102, #D374,103, #D374,498, #D382,077,  
#D393,325, #D397,495, #D397,494, #D403,101,  
#D435,686, #D454,973, #D454,974, #D455,224,  
#D456,940, #D463,602S, #D463,603S, #D464,769S,  
#D468,480, #2,651,806, #5,104,082, #5,109,325,  
#5,116,009, #5,144,541, #5,205,644, #5,222,805,  
#5,241,460, #5,255,173, #5,258,900, #5,285,364,  
#5,404,285, #5,460,269, #5,567,046, #5,567,468,  
#5,573,330, #5,577,838, #5,588,744, #5,873,652,  
#5,906,430, #5,921,668, #6,241,370B1 & #6,712,490B2

## CHANDELIER 5797S TRIM DIAGRAM

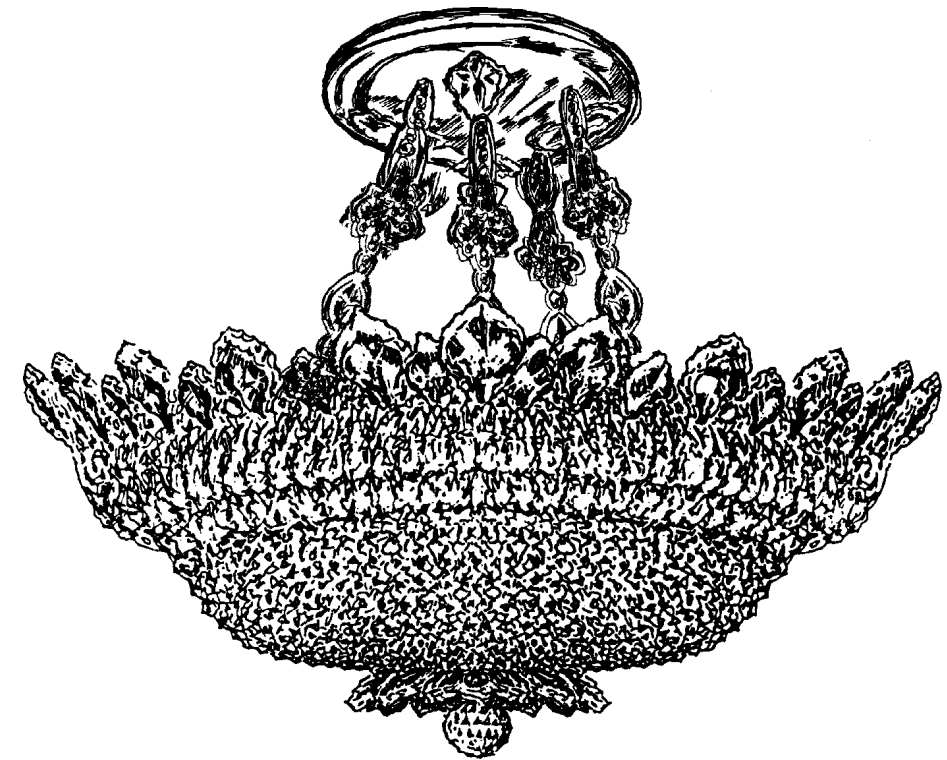

**T**HIS DESIGN IS THE PROPRIETARY TRADE DRESS/TRADE MARK OF SCHONBEK WORLDWIDE LIGHTING INC.

10 Lights  
Diameter: 24"  
Body Length: 19"

# SCHONBEK®

This fixture was designed and manufactured in Plattsburgh, N.Y. Our high-quality crystal fixtures are made with state-of-the-art manufacturing equipment. If you have any questions about this or any of our more than 450 crystal products, contact your nearest authorized Schonbek distributor.

**CAUTION... RISK OF ELECTRICAL SHOCK.** Make sure the electrical supply to the chandelier is turned off at the main fuse or circuit breaker before doing any installation. All electrical components must be installed by a licensed electrician in accordance with the National Electric Code and the appropriate local electrical codes.

HANGING WEIGHT: 20 pounds.

**BULBS:** (8) Candle shaped candelabra base C10 bulbs  
(2) Globe shaped candelabra base G16-1/2 bulbs  
Recommend 25 watts for best appearance.  
60 - Watts Maximum

**WARNING:** This chandelier meets UL/CSA requirements. Any tampering will void UL/CSA certification.

**Follow steps in exact order  
Save this trim diagram for future reference**

**1**

### IMPORTANT

**Person who opens carton should record the following information for future service.**

**CODE #** \_\_\_\_\_ Four-digit number on outside of carton.  
**PACKER #** \_\_\_\_\_ See crystal package label.  
**ORDER #** \_\_\_\_\_ See crystal package label.

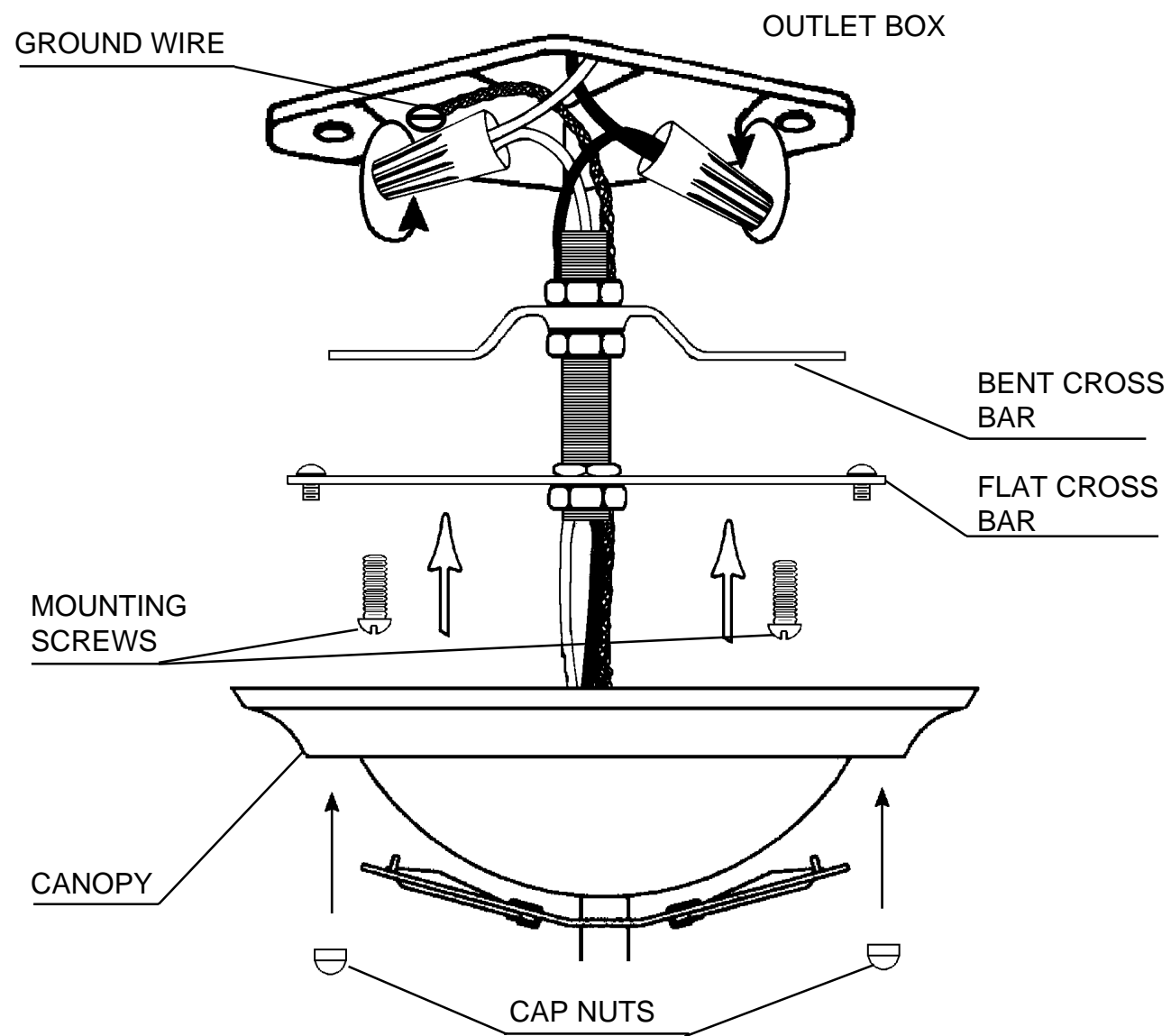

- 2 MAKE SURE POWER IS DISCONNECTED!!**
- 3** Attach crossbars to outlet box.
- 4** Again, make sure that power to the outlet box is disconnected. Attach stem wires to power wires in outlet box. Fixture **MUST** be properly grounded.
- 5** Attach canopy to ceiling with cap nuts, thereby retaining complete fixture against ceiling.
- 6** Screw bulbs into all sockets. Test power to insure proper wiring before hanging trim from fixture.

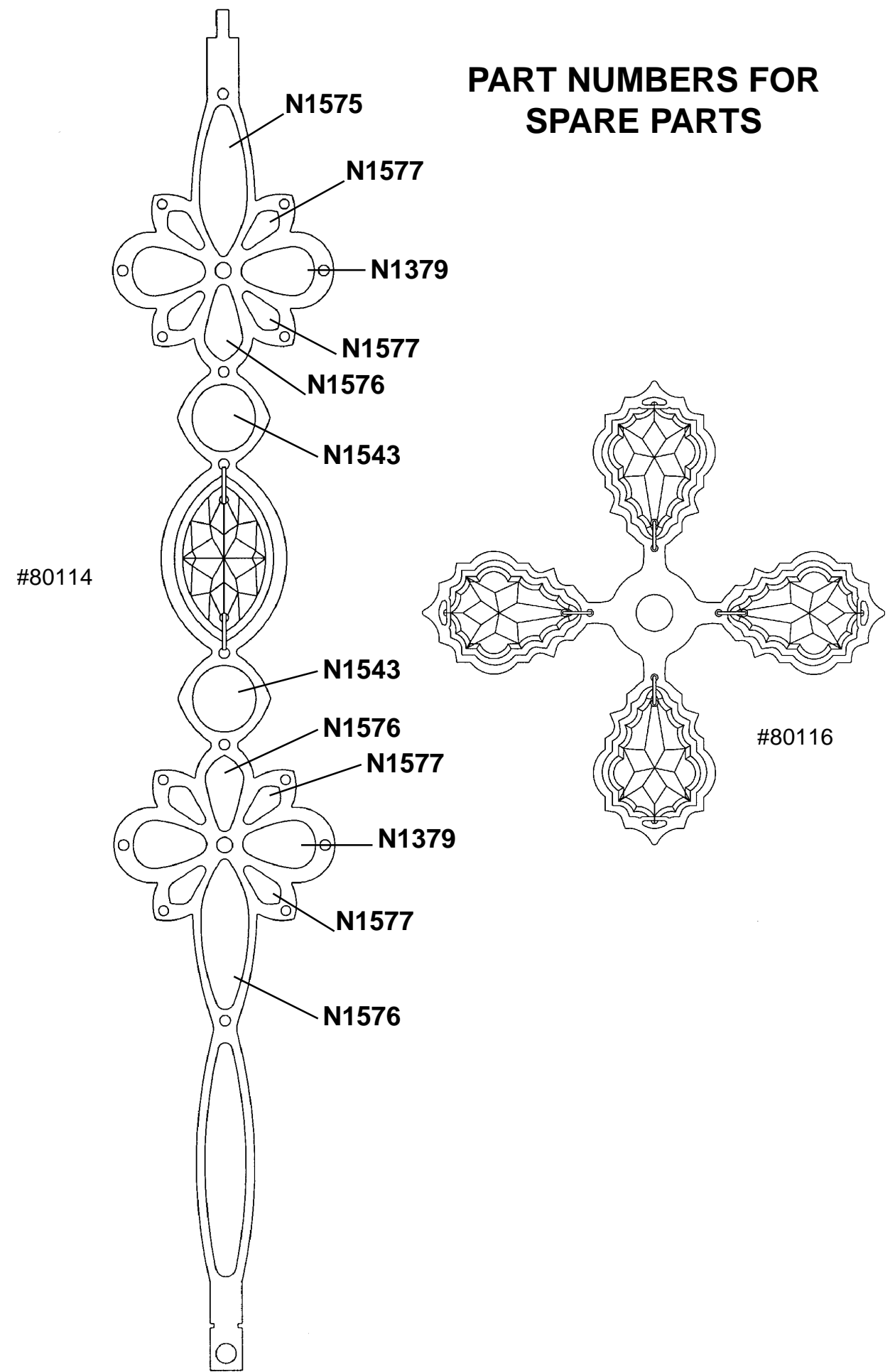

### Installation of Crystal "B"

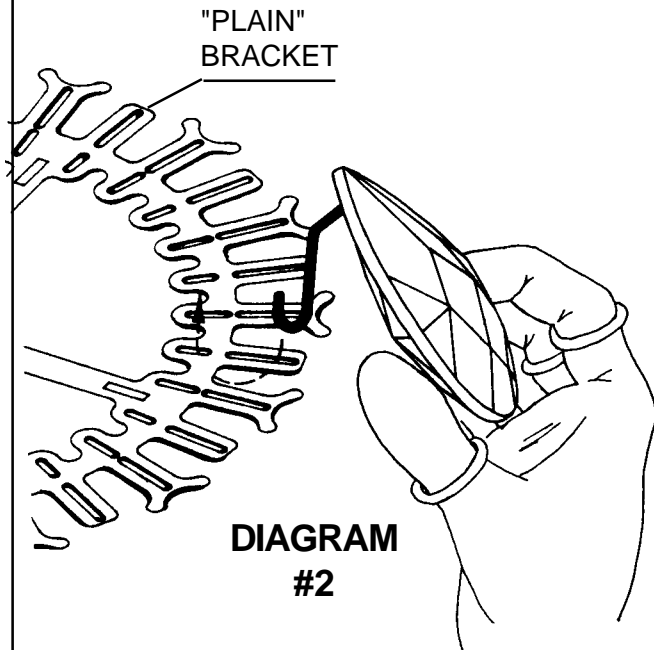

DIAGRAM #2

Position the crystal above the "plain" bracket so that the end of the hook enters the slot, gently push toward the center of the fixture and raise the crystal making sure that the end of the hook comes up through the inner slot, in line with the outer slot.

With the hook in the bracket, as shown, pivot the crystal downwards so that the hook rests in the end of the outer slot.

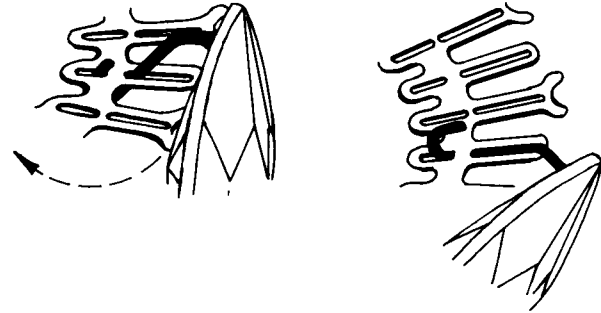
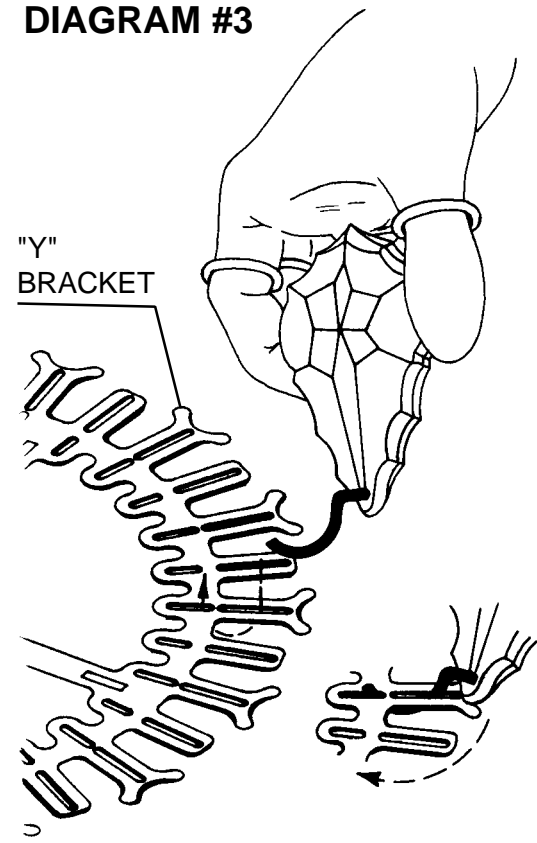

DIAGRAM #3



### Installation of Crystal "C" and "D"

Position the crystal above the "Y" bracket so that the end of the hook enters the long slot, gently push toward the center of the fixture and raise the crystal making sure that the end of the hook comes up through the short slot, in line with the long slot.

With the hook in the bracket, as shown, pivot the crystal downwards so that the hook rests in the end of the long slot.

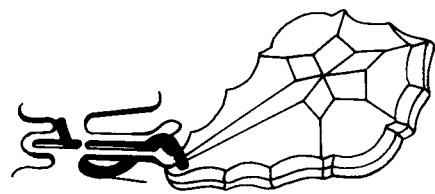

## TRIM ID SHEET FOR ORDERING SPARE PARTS. PLEASE SAVE FOR CLEANING FIXTURE!

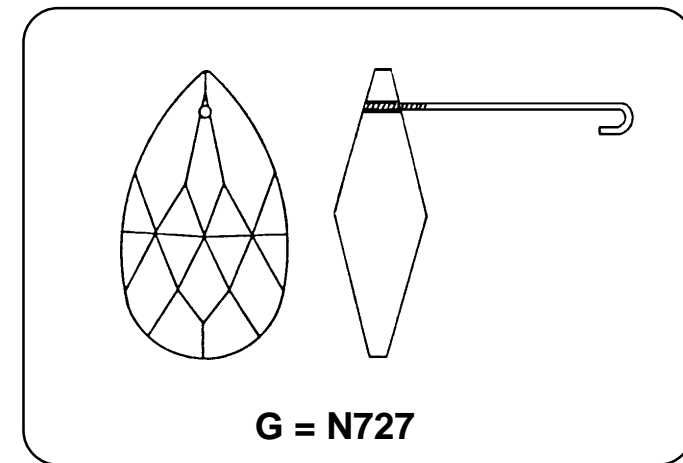
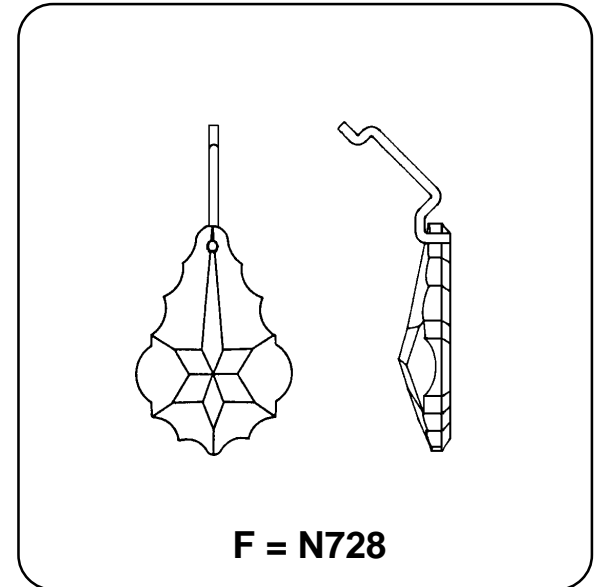
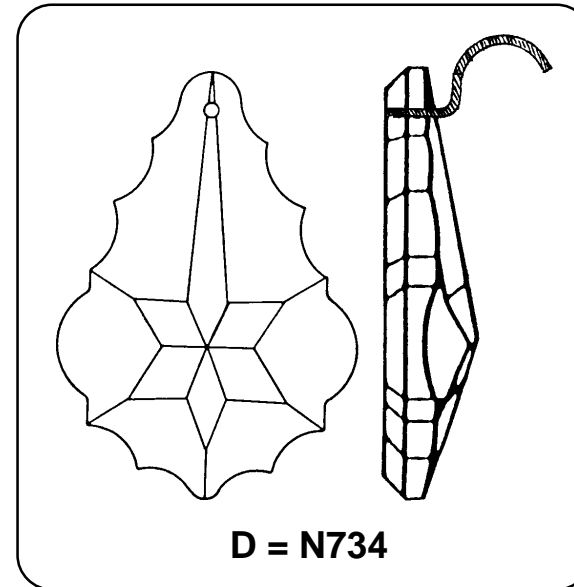
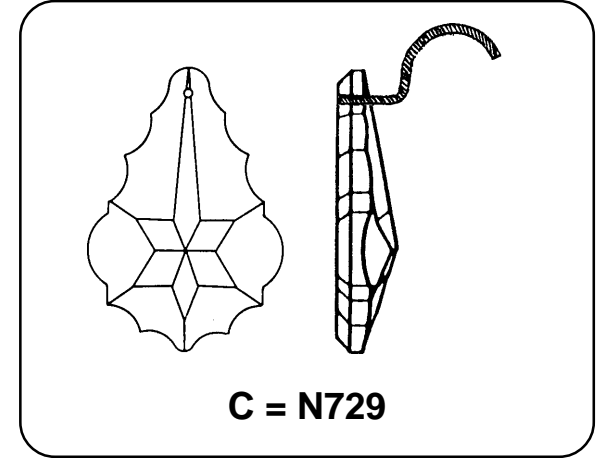
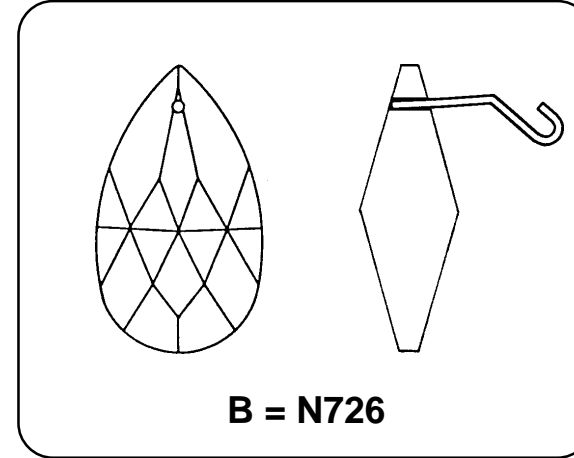

**7** Screw finial assembly onto bottom of chandelier. Hook Crystal Chain "E" (large crystal towards top) into the ring #2. Allow bottom of chain to hang freely.

**8** Hook Crystal "F" into the lexan washer on the finial assembly. See diagram #1 for detailed instructions.

**9** Hook the bottom of Chains "E" into the lexan washer. Close bottom hook after inserting into lexan washer.

**10** Hook Crystal "G" into the back slot of the "Y" bracket of ring #1. See diagram #2 for detailed instructions.

**11** Hook Crystal "B" into the "plain" bracket of ring #1. See diagram #3 on page 6.

**12** Hook small Crystal "C" into every second "Y" bracket of ring #1. See diagram #4 on page 6.

**13** Hook large Crystal "D" into the remaining "Y" brackets of ring #1. See diagram #4 on page 6.

