



SCHONBEK®

SONATINA ST1946N- __ __S



10 Lights
Diameter: 25-1/2"
Height: 29-1/2"
Hanging Weight: 25lbs.

THIS DESIGN IS THE PROPRIETARY
TRADE DRESS/TRADEMARK OF
SWAROVSKI LIGHTING, LTD.



SCHONBEK®

MAX <u>60</u> W		110-120 V						

SCHONBEK® is a member of the Swarovski group.

WARNING:

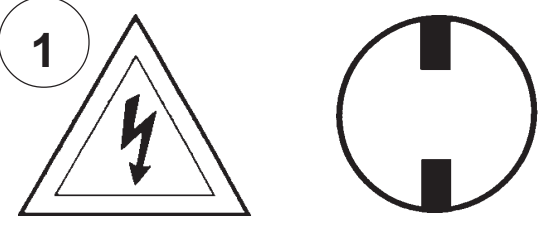
1 

Electrical Danger Turn Power Off

All electrical components must be installed by a licensed electrician in accordance with the National Electric Code and the appropriate local electrical codes.

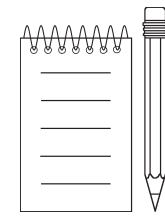
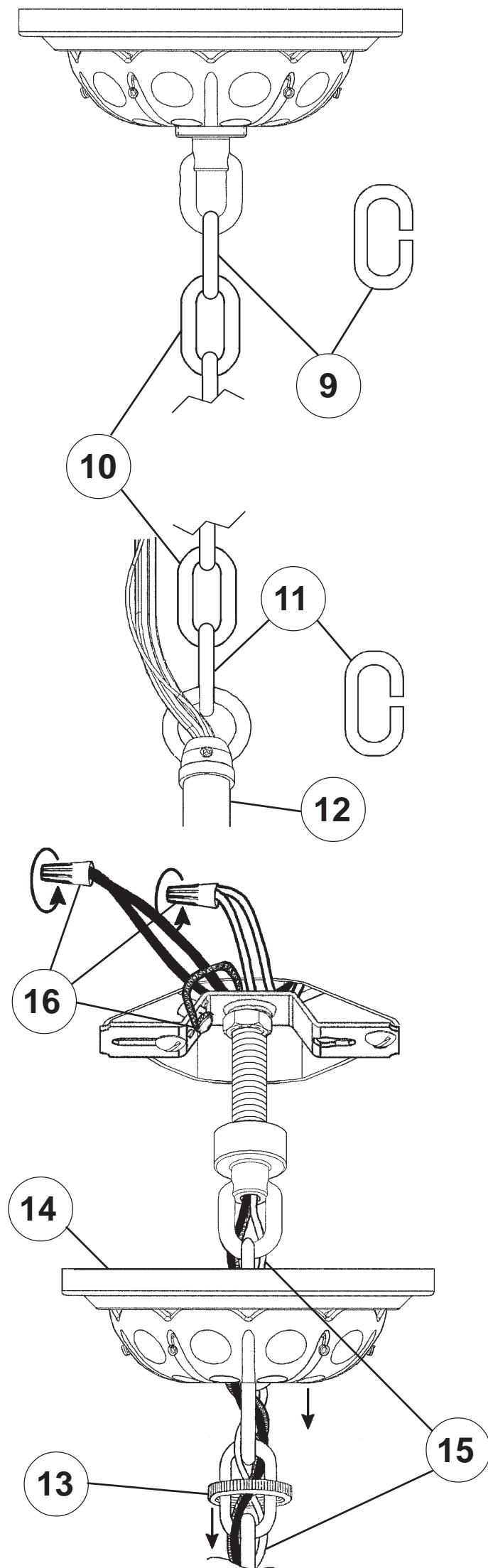
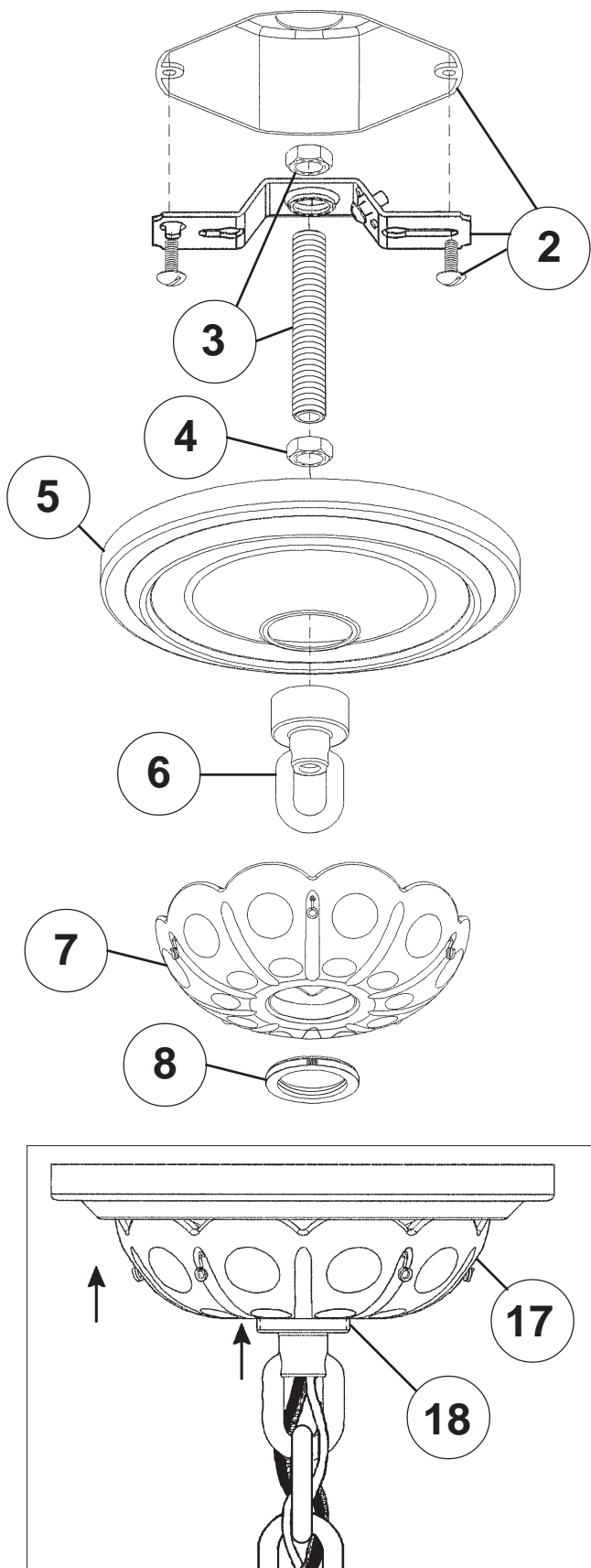

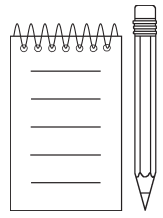

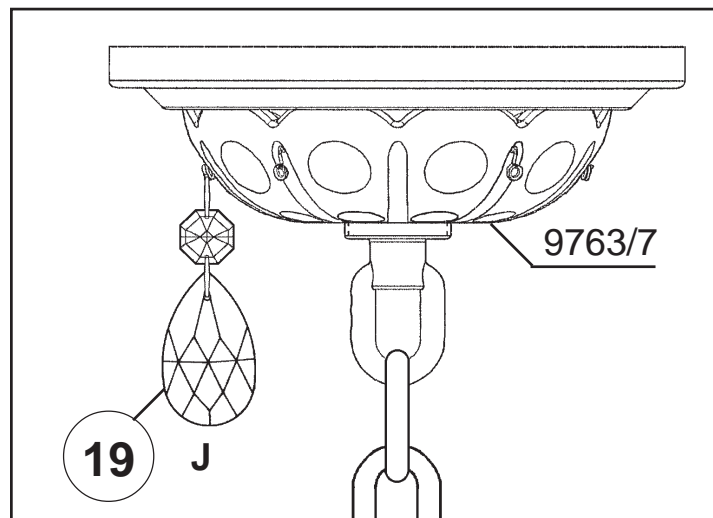

20

You will need 10 - B10
25 Watts Recommended
60 Watts Max

**Install bulbs and be
sure to test fixture
BEFORE trimming.**

